



ILLUSTRATIONS

EXAMPLE OF APPROVED HURDLE

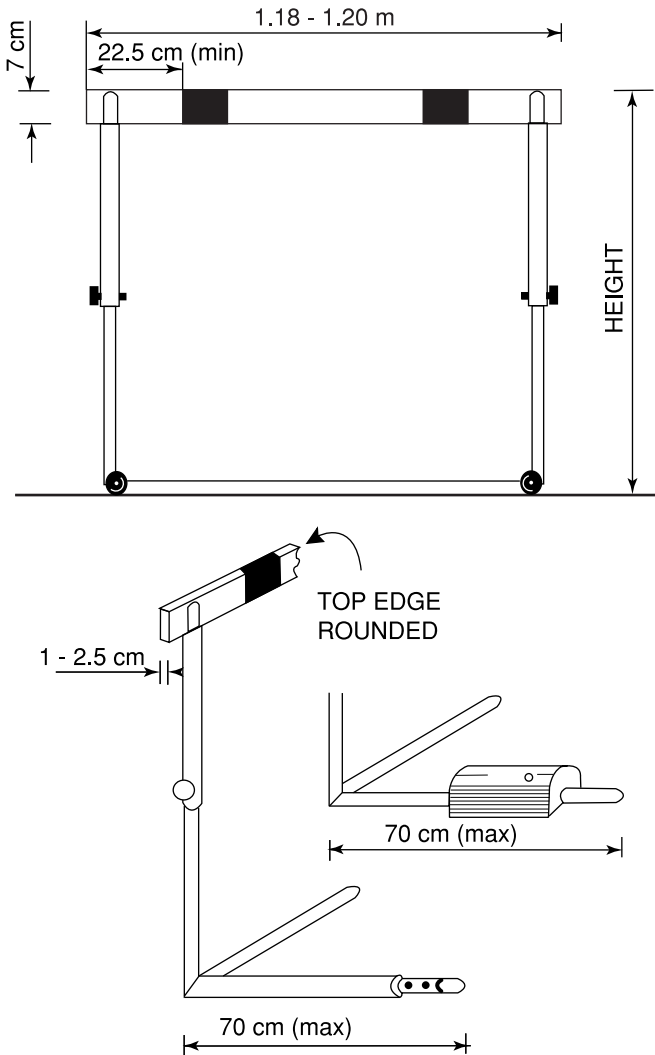
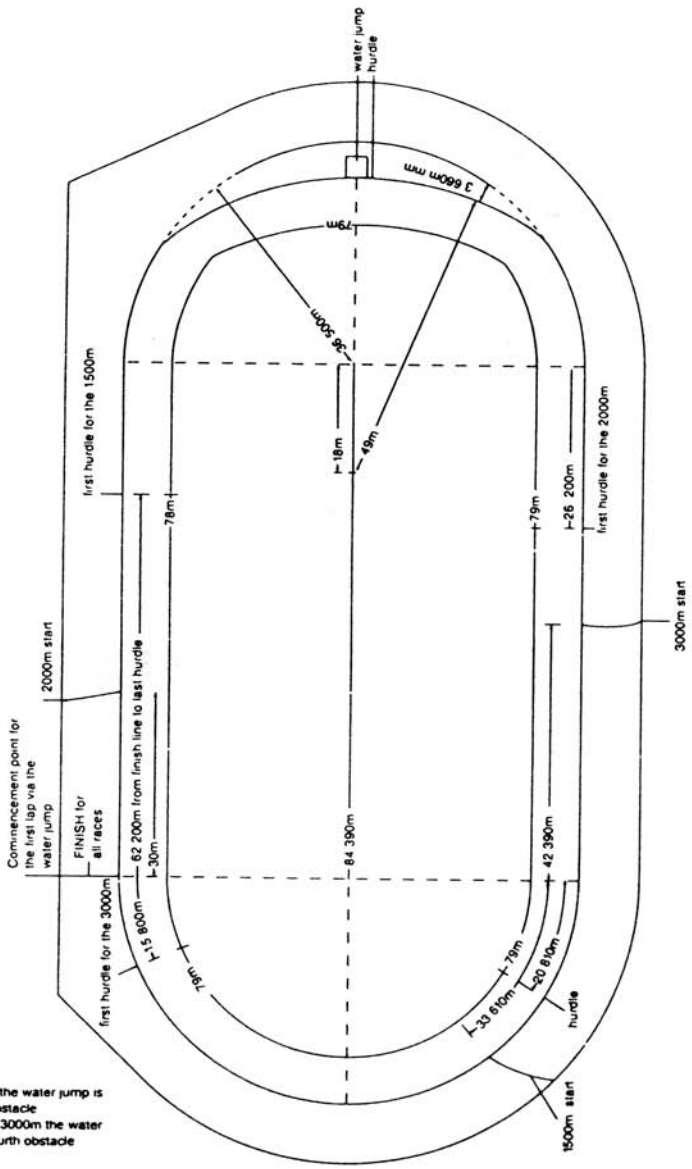

FIGURE 1



In the 2000m the water jump is the second obstacle
 in the 1500 & 3000m the water jump is the fourth obstacle

FIGURE 2

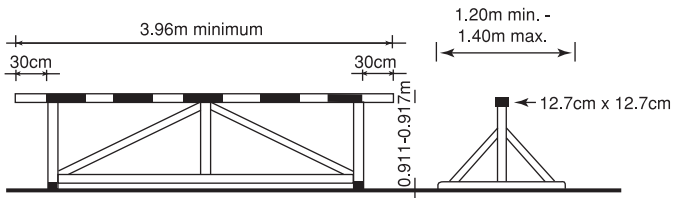

FIGURE 3 – STEEPLCHASE BARRIER

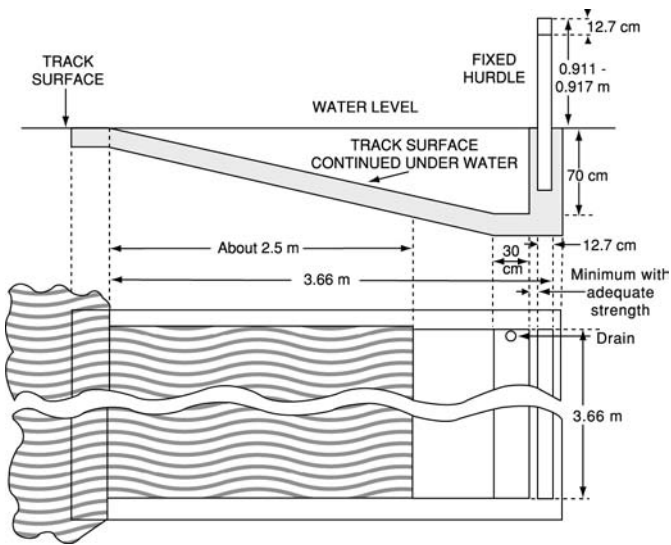
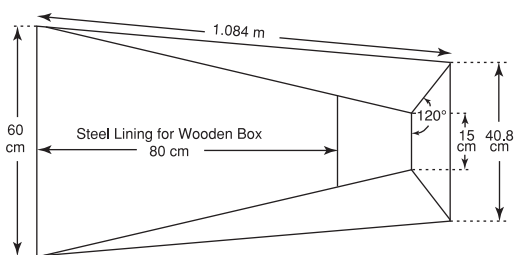
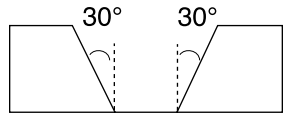
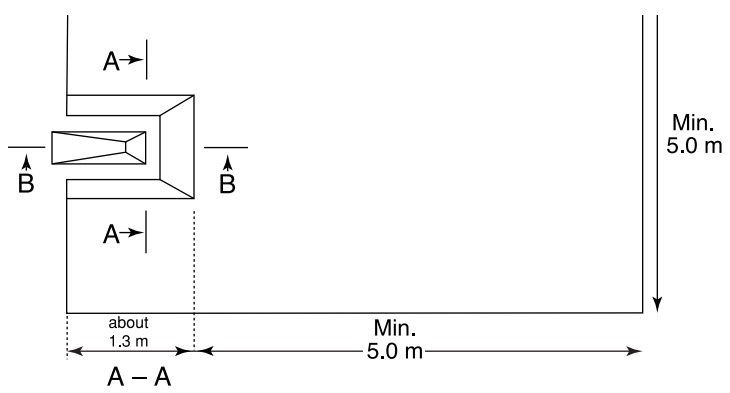
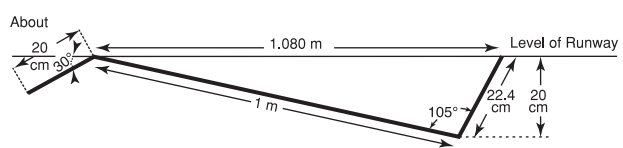

FIGURE 3 – WATER JUMP



PLAN VIEW



Plan of a Suitable Landing Area

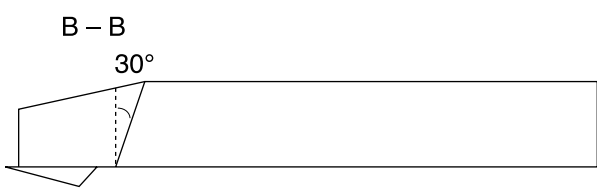

FIGURE 5 – POLE VAULT BOX AND LANDING AREA

FIGURE 6 – TAKE-OFF BOARD AND PLASTICINE BOARD

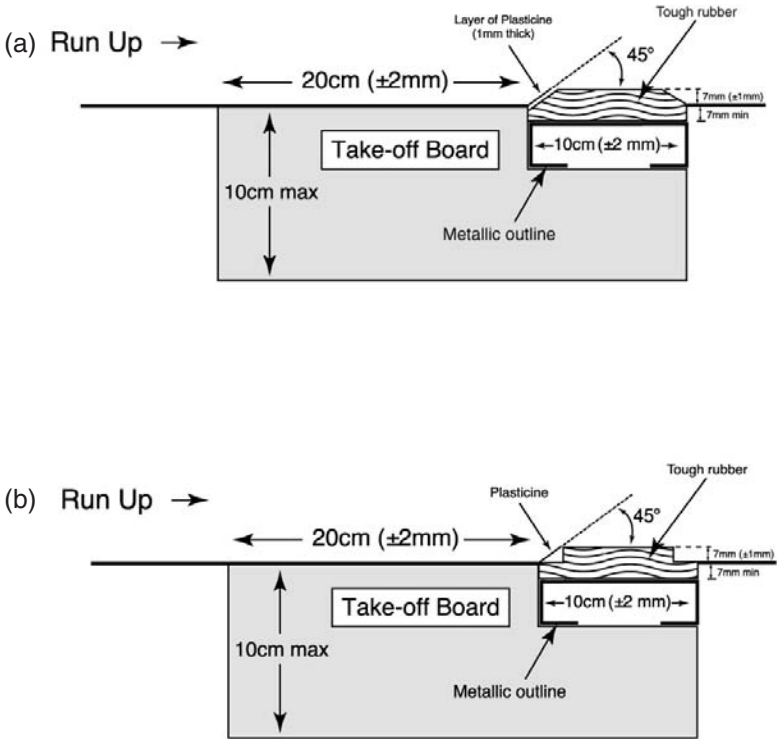

FIGURE 7 – END VIEW OF CROSSBAR

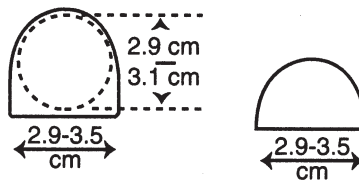

FIGURE 8 – LAYOUT OF CONCENTRIC CIRCLES FOR DISCUS AND HAMMER

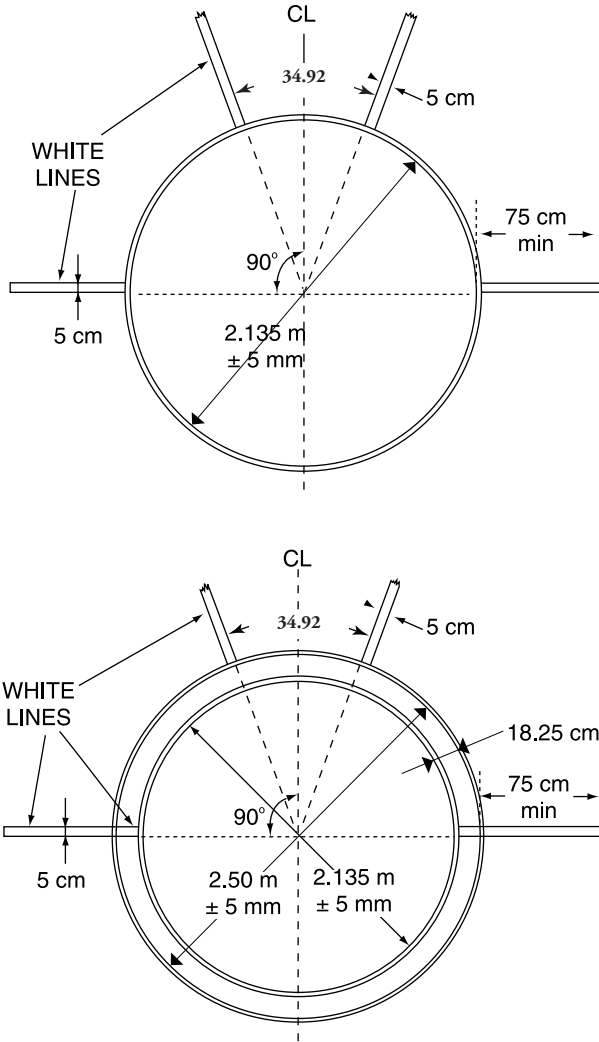

FIGURE 9 – LAYOUT OF SHOT STOPBOARD

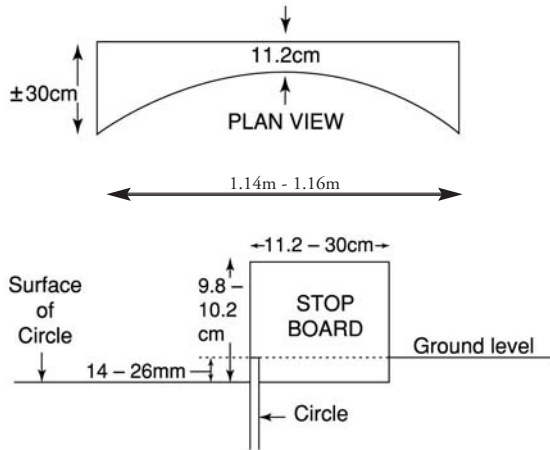

FIGURE 10 – DISCUS

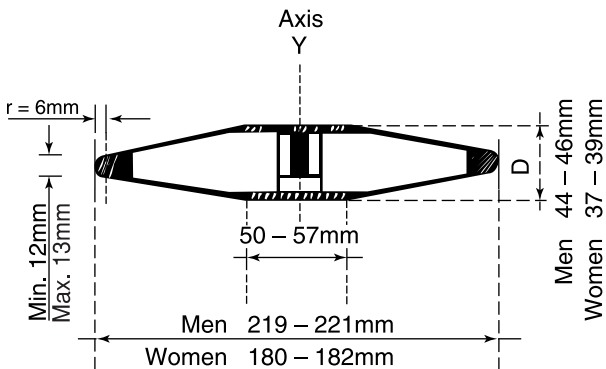
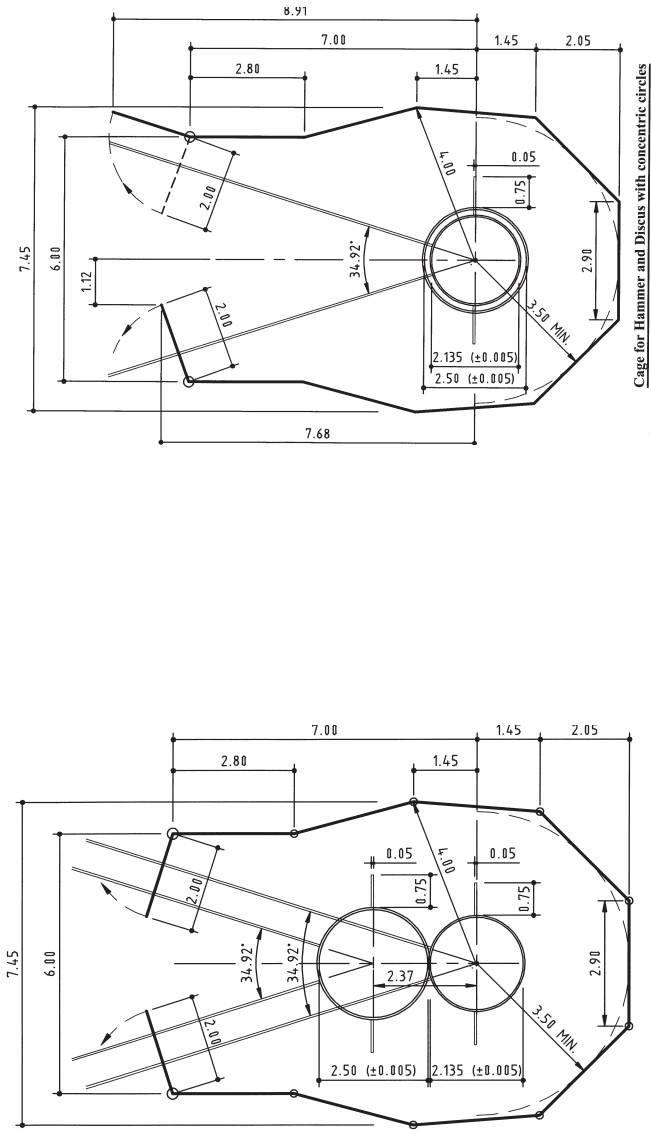

FIGURE 12 – HAMMER/DISCUS CAGE LAYOUTS



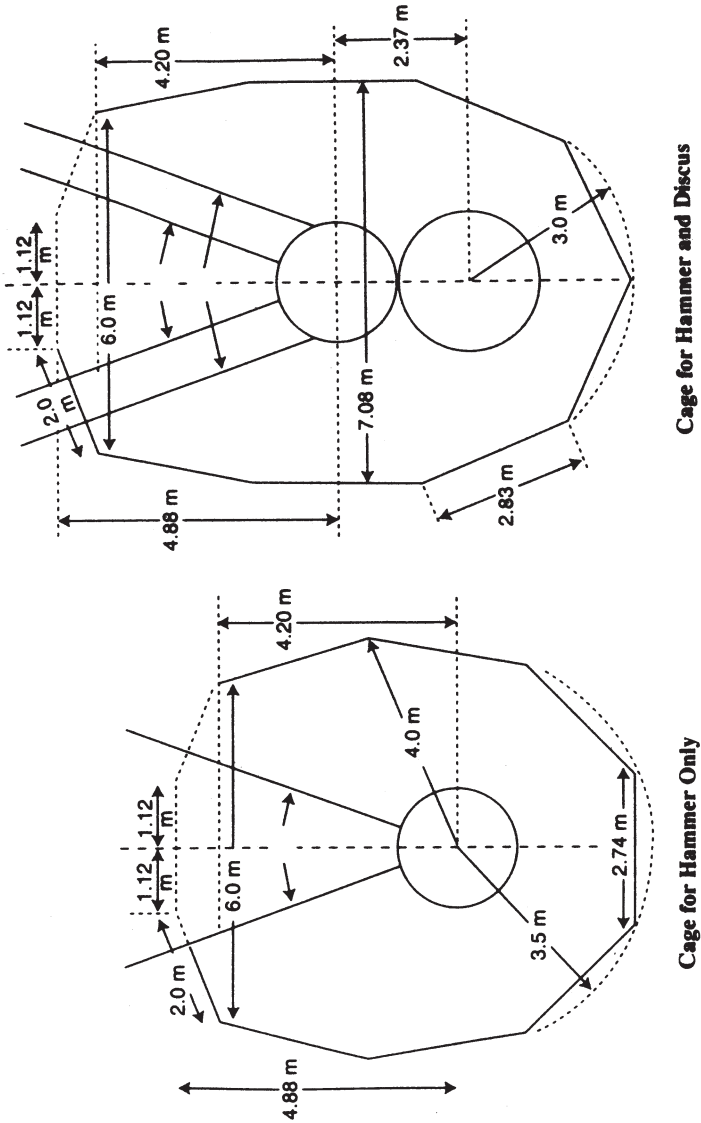

FIGURE 13 – PLANS OF ARTERNATIVE HAMMER CAGES